

WHO WANTS TO BE A NUMBER

MILLIONAIRE

Numeracy Challenge

Teacher Resource Manual 1

Published in 2009 by
Junior Certificate School Programme Support Service
Curriculum Development Unit
Captain's Road
Crumlin
Dublin 12
Phone: 01 453 5487
Fax: 01 453 7659
Email: jcsp@iol.ie

Copyright © Junior Certificate School Programme Support Service 2009

The Junior Certificate School Programme Support Service is funded by the Teacher Education Section, Department of Education and Science and the European Social Fund.

The Junior Certificate School Programme Literacy and Numeracy Strategy and the Demonstration Library Project are funded by the Early Literacy Initiative and the Delivering Equality of Opportunity in Schools (DEIS) Action Plan within the Teacher Education Section of the Department of Education and Science.

The Junior Certificate School Programme is a national programme sponsored by the Department of Education and Science and the National Council for Curriculum and Assessment.

The Support Service for the Junior Certificate School Programme is based in the CDVEC Curriculum Development Unit
Captain's Road
Crumlin
Dublin 12

Written by Jerry McCarthy

Edited by Mary Clare Higgins and Hilary Cantwell



JCSP “Number Millionaire” Initiative

“Number Millionaire” is a numeracy quiz where individual students (contestants) are challenged to identify the correct answer to each of twelve arithmetical questions. Each quiz question has a choice of four answers attached; three of the answers are incorrect. The student can identify the correct answer by performing mental computation and / or deduction. The quiz questions are based on the following numerical concepts and competencies: addition, subtraction, multiplication, division, whole numbers, fractions, decimals, percentages, square numbers, even and odd numbers, greater than and less than, remainders, equivalences, properties of regular shapes, properties of angles, properties of time and telling the time, calendar, sequences, simple equations.

Each contestant has four “Lifelines” available to him / her when faced with a difficult question, namely:

- **“Ask the Class”**
- **“50 : 50”**
- **“Use a Friend” (use a calculator)**
- **“Ask a Friend”.**

Each Lifeline can be used only once by a contestant. When the contestant has used up all his / her Lifelines, he / she must either answer the next question or withdraw from the quiz and leave with his / her existing total of points.

Points are allocated, on a sliding scale, for calculating and identifying the correct answer to a question. The questions in the later rounds of the quiz are more difficult and demanding than the questions encountered in the earlier rounds. To acquire the maximum number of points (One Million) in the quiz and be awarded a “Number Millionaire” certificate, the contestant must correctly answer each of the 12 consecutive quiz questions.

The student is challenged to attain the greatest number of points by answering as many questions as he / she can. The quizmaster always checks with the contestant that he / she is happy with his / her initial choice of answer and confirms that he / she does not want to change his / her choice. This selection of “my Final Answer” cannot be changed. At the same time, the rest of the class are told to work out and think of the answer as well, because the contestant might opt to "Ask the Class" if he / she is faced with a difficult question.

Selecting an incorrect “final” answer eliminates a contestant from the quiz.

The teacher should take time to “sell” the quiz to the students and to describe, model and demonstrate the dynamics and rules of the quiz. Reference should be made to the way contestants are selected, how points are acquired, how the “Safe Havens” work and how students can opt to make use of the four types of “Lifelines”.

The quiz is usually planned and structured as an individualised activity, involving one contestant at a time, but can also be implemented as a paired and collaborative activity involving two students.

The quiz is an effective medium for revising important numerical concepts and competencies. Follow-up discussions in class about the strategies and approaches, that were employed to calculate and identify the correct answer to specific questions, can be a valuable learning experience for the students by stimulating reflection, by providing opportunities for recapitulation and by increasing the students' repertoire of problem solving strategies and computational approaches.

The quiz content prioritises mental computation and provides a framework to support the development and extension of numerical understanding, skills and competencies. It can develop confidence in performing numerical and arithmetical operations, enhance mental computation, strengthen cognitive reasoning, improve pace of response and revise, reinforce and activate existing mathematical knowledge and understanding. It is also an activity that introduces a fun element to the teaching and learning of maths in a classroom setting. The "Number Millionaire" quiz can be structured as a recreational activity or as a planned and timetabled component in the maths classroom. A celebration event should be organised at the culmination of the quiz to acknowledge the students' engagement, achievements and success. "Number Millionaire" achievement certificates can be used to celebrate and acknowledge the students' achievements.

Allocating points:

Gateway questions	no points allocated
First answer correct:	500 points
Second answer correct:	1,000 points
Third answer correct:	2,000 points
Fourth answer correct:	5,000 points
Fifth answer correct:	10,000 points
Sixth answer correct:	20,000 points
Seventh answer correct:	50,000 points
Eight answer correct:	75,000 points
Ninth answer correct:	150,000 points

Tenth answer correct:	250,000 points
Eleventh answer correct:	500,000 points
Twelveth answer correct:	1,000,000 points

Reaching the three “Safe Havens”

The bolded points-values on the scoring scale indicate “Safe Havens”. The Safe Havens are the values of the 1,000 and 50,000 and 250,000 points questions. Once you cross the 1,000 points mark, you can't leave the quiz with less than 1,000 points.

If you successfully pass the 50,000-point question, you're guaranteed to leave with at least 50,000 points. Once you successfully pass the 250,000-point question, you're guaranteed to leave with at least 250,000 points.

A contestants can also walk away with the points total that he / she has already won if he / she decides to “take my winnings” and not risk getting an incorrect answer to the next question, after hearing the content to that question. When an incorrect answer is provided by the contestant, he / she is eliminated from the quiz and his / her points-total and winnings drop down to the value of the last safe haven question answered.

The appendix section in the Teacher’s Manual contains a wide selection of numerical questions.

Planning and Implementing the Quiz

Teachers are provided with the following resources:

- **Number Millionaire, Teacher Resource Manual 1 (quiz questions)**
- **Number Millionaire, Teacher Resource Manual 2 (quiz questions with correct answers underlined)**
- **Starter Pack / Booklet of Blank Templates**
- **Selection of Quiz Cards**

Additional quiz cards can be created in the blank templates – using either your own teacher-developed questions or a selection of questions from the suite of questions that are provided in this Teacher Manual 1.

Question cards can be colour coded and arranged to correspond with the level and category of challenge that they present.

Some schools may also consider laminating these question cards to ensure an extended lifespan for the cards.

Two copies of each question-card (and associated answers) will be required for the quiz: one copy is retained by the quizmaster and the other hardcopy is presented to the contestant as a visual prompt and stimulus to complement the question being asked orally by the quizmaster.

This Teacher Manual 1 contains a wide selection of numerical / arithmetical questions. These questions have been grouped into five categories, namely:

- **“Gateway” questions. No points are awarded.**
- **Category 1: 500-point questions and 1,000-point questions**
- **Category 2: 2,000-point questions, 5,000-point questions, 10,000-point questions, 20,000-point questions and 50,000-point questions.**
- **Category 3: 75,000-point questions, 150,000-point questions and 250,000-point questions**
- **Category 4: 500,000-point questions and 1,000,000-point questions.**

Other than the Gateway questions, each quiz question has a multi-choice selection of answers.

The teacher usually performs the role of quizmaster but a student can also perform this role.

The teacher also monitors the Gateway selection process, the contestant’s use of Lifelines and the total of points awarded.

Teachers can increase the selection and variety of questions available for the quiz by planning and developing their own bank of questions and lists of answers. Teacher-generated quiz questions can include some specific topic or content that the teacher wishes to revise with the students.

A calculator should be available if the contestant opts for the Lifeline of “Use a Friend”.

The quiz-master should:

- **orally ask the question**
- **provide the contestant with the question card which contains the written version of the question (and the four multi-choice answers)**
- **provide sufficient time to the student to process his / her answer.**

Once the contestant has given an answer, the teacher should confirm that this is his / her “Final Answer”.

When a contestant seeks the support of the audience (“Ask the Class”), the teacher should repeat the question to the class.

Placing “Number Millionaire” posters on display in the school can help to generate excitement in the forthcoming quiz.

JCSP stickers can be used to illustrate and identify the total points achieved by each contestant.

Selection of Contestants (The “Gateway” Question):

The teacher selects a student to play the game by asking a “Gateway” question. The student who gives the “correct answer quickest” comes to the front of the class to sit in the “hot seat” and play in the “Number Millionaire” quiz.

The selection of contestants can also be determined by:

- the random selection of names from a hat
- spinning a dice (after giving each student a number on the dice: several spins of the dice may be required to select the eventual “winner”)
- on a rotational basis, so that every student has an opportunity to participate (e.g. using the alphabetical sequence of the students’ surnames)
- having a "Fastest Finger Question" where students can use their calculators to give the quickest correct answer to the Gateway question

The Four Lifelines

Four types of Lifelines are available to the contestant. Each Lifeline can be used only once.

1. Ask the Class (Audience)

The contestant asks the class for assistance. Each member of the class provides an answer. The teacher summarises the audience’s responses and identifies the most popular answer / the second most popular answer etc. The contestant can then decide to use one of the audience’s answers or stay with his own self-developed answer.

2. Ask A Friend

The contestant asks some named member of the audience (the class) for assistance. This selected student provides an answer to the contestant. The contestant can then decide to use this student’s answer or stay with his own self-developed answer.

3. Use A Friend (Calculator)

The student can request to use a calculator to arrive at an answer to the quiz question.

4. 50-50

The student can request that two incorrect answers are taken away by the teacher from the original choice of four answers. This means that a choice of two answers remain, one incorrect and one correct.

Insights from Research

The successes, effectiveness and appropriateness of employing a gaming and fun approach to support the development of numerical and mathematical understanding had been clearly documented in educational research literature. Hughes (1983) and Rogers and Miller (1984) claim that, when mathematical and numerical content and process can be contained and replicated in play or game format, motivation for learning becomes enhanced and the inherent enjoyment and success can foster positive attitudes to the self and to numeracy and mathematics. Kirkby (1992) states that numerical games and quizzes require children to think that perform more calculations mentally than they could possibly record on paper in the same time. Topping and Ehly (1998) state that fun activities in numeracy and mathematics improve the student's time on task and level of engagement, provide opportunities for cognitive revision and restructuring and improve self-confidence, self belief and self efficacy.

LIFELINE

ASK THE CLASS



Number Millionaire

LIFELINE

ASK A FRIEND



Number Millionaire

LIFELINE

USE A FRIEND



Number Millionaire

LIFELINE

50 : 50

Eliminate 2 Incorrect Answers



Number Millionaire

Are You Sure?

**Is this Your Final
Answer?**

Some Quiz Questions

(correct answer not indicated)

“Gateway” Questions

1. Which number will not divide equally by 5 (with no remainder)?

15 25 12 30

2. Which number will not divide equally by 4 (with no remainder)?

15 16 12 40

3. Which number will not divide equally by 3 (with no remainder)?

15 24 12 40

4. Which number will not divide equally by 6 (with no remainder)?

12 6 18 40

5. Which number will not divide equally by 7 (with no remainder)?

14 21 12 28

6. Which number will not divide equally by 10 (with no remainder)?

10 20 12 40

7. Which number will not divide equally by 5 (with no remainder)?

25 65 12 40

8. Which number will not divide equally by 5 (with no remainder)

55 25 17 20

9. What is $\frac{1}{2}$ of 24?

10. What is $\frac{1}{2}$ of 14?

11. What is $\frac{1}{2}$ of 20?

12. What is $\frac{1}{2}$ of 22?
13. What is $\frac{1}{2}$ of 18?
14. What is $\frac{1}{2}$ of 16?
15. What is $\frac{1}{2}$ of 26?
16. What is $\frac{1}{2}$ of 30?
17. What is $\frac{1}{2}$ of 28?
18. What is $\frac{1}{2}$ of 32?
19. How many sides in a triangle?
20. How many sides in a square?
21. How many sides in a rectangle?
22. How many sides in a parallelogram?
23. How many even numbers are there between 1 and 9?
24. How many odd numbers are there between 1 and 9?
25. Doubling a number is the same as multiplying it by which Number?
26. Halving a number is the same as dividing it by which number?
27. Squaring a number is the same as multiplying it by...?
28. What is the largest whole number you can make from these digits:
1 5 4
29. What is the smallest whole number you can make from these digits:
6 8 4

30. Double 23 gives:
31. Double 43 gives:
32. Double 54 gives:
33. Double 27 gives:
34. Twice 36 is:
35. Twice 45 is:
36. Twice 43 is:
37. Twice 37 is:
38. Twice 39 is:
39. Twice 48 is:
40. Twice 120 is:
41. Twice 144 is:
42. Half of 56 is:
43. Half of 68 is:
44. Half of 76 is:
45. Half of 84 is:
46. Half of 96 is:
47. 22 less than 56 is:
48. 28 less than 56 is:
49. 25 less than 76 is:
50. 22 less than 78 is:

51. **22 less than 86 is:**
52. **27 more than 56 is:**
53. **34 more than 63 is:**
54. **27 more than 59 is:**
55. **19 more than 86 is:**
56. **28 more than 66 is:**
57. **What is the total of: 8, 19 and 7 ?**
58. **What is the total of: 18, 9 and 5 ?**
59. **What is the total of: 28, 17 and 6 ?**
60. **What is the total of: 19, 15 and 9 ?**
61. **What is the total of: 23, 13 and 8 ?**
62. **233 minus 12 gives:**
63. **244 minus 16 gives:**
64. **255 minus 22 gives:**
65. **263 minus 17 gives:**
66. **272 minus 19 gives:**
67. **334 minus 15 gives:**
68. **278 minus 18 gives:**
69. **214 take away 67 gives:**
70. **324 take away 56 gives:**
71. **414 take away 43 gives:**
72. **292 take away 26 gives:**

73. **543 take away 27 gives:**
74. **866 take away 76 gives:**
75. **437 take away 26 gives:**
76. **278 take away 77 gives:**
77. **214 take away 56 gives:**
78. **417 take away 26 gives:**
79. **567 take away 44 gives:**
80. **458 take away 33 gives:**
81. **815 take away 19 gives:**
82. **419 take away 45 gives:**
83. **325 take away 32 gives:**
84. **What number must be added to 37 to make 75?**
85. **What number must be added to 47 to make 78?**
86. **What number must be added to 38 to make 79?**
87. **What number must be added to 27 to make 75?**
88. **What number must be added to 17 to make 76?**
89. **What number must be added to 34 to make 65?**
90. **What number must be added to 27 to make 66?**
91. **What number must be added to 33 to make 57?**
92. **What number must be added to 35 to make 95?**
93. **What number must be added to 31 to make 96?**

94. What number must be added to 33 to make 78?
95. **A film begins at 7:15 p.m. and lasts for one hour and thirty minutes. What time does the film end?**
96. A train leaves Cork (Kent station) at 7:30 a.m. and takes two hours and forty-five minutes to reach Dublin. What time does the train arrive in Dublin (Heuston)?
97. **A pop concert begins at 10:15 p.m. and lasts for two hours and thirty-five minutes. What time does the concert end?**
98. How many degrees are there in a right angle?
99. **If the length of the diameter of a circle is 12cm, what is the length of its radius?**
100. What fraction of a circle is a semi-circle?
101. **How many right angles are there in a square?**

Category 1:

500 Point Questions
1000 Point Questions

1. "Seven thousand, one hundred and forty-five" in figures is:
(A) 7451 (B) 7154 (C) 7145 (D) 7155 ✓
2. "Six thousand, three hundred and seventy-five" in figures is:
(A) 6357 (B) 6753 (C) 6573 (D) 6375 ✓
3. "Nine thousand, eight hundred and forty-nine" in figures is:
(A) 9849 (B) 9894 (C) 8949 (D) 9489 ✓
4. "Ten thousand, six hundred and seventy-eight" in figures is:
(A) 10, 668 (B) 10, 768 (C) 10,678 (D) 10, 786 ✓
5. "Eight thousand, four hundred and seventy-five" in figures is:
(A) 8448 (B) 8457 (C) 8748 (D) 8475
6. What is the figure 3 worth in the number 9836?
(A) Three hundreds (B) Three tens (C) Three units
(D) Three thousands
7. What is the figure 8 worth in the number 9836?
(A) Eight hundreds (B) Eight tens (C) Eight units
(D) Eight thousands
8. What is the figure 6 worth in the number 9836?
(A) Six hundreds (B) Six tens (C) Six units
(D) Six thousands
9. What is the figure 9 worth in the number 9836?
(A) Nine hundreds (B) Nine tens (C) Nine units
(D) Nine thousands

10. What is the figure 4 worth in the number 34217?
(A) Four hundreds (B) Four tens (C) Four units
(D) Four thousands
11. What is the figure 1 worth in the number 34217?
(A) One hundred (B) One ten (C) One unit
(D) One thousand
12. What is the figure 7 worth in the number 34217?
(A) Seven hundreds (B) Seven tens (C) Seven units
(D) Seven thousands
13. What is 7 more than 345?
(A) 362 (B) 355 (C) 352 (D) 372
14. What is 8 more than 235?
(A) 253 (B) 255 (C) 234 (D) 243
15. What is 7 more than 555?
(A) 562 (B) 572 (C) 682 (D) 526
16. What is 8 less than 267?
(A) 258 (B) 259 (C) 269 (D) 248
17. What is 5 more than 342?
(A) 349 (B) 348 (C) 347 (D) 357
18. What is 9 less than 295?
(A) 286 (B) 276 (C) 266 (D) 289
19. What is 8 more than 435?
(A) 454 (B) 453 (C) 443 (D) 452
20. What is 7 less than 253?
A) 236 (B) 244 (C) 245 (D) 246 ✓
21. What is 6 more than 365?
(A) 373 (B) 371 (C) 372 (D) 374 ✓

22. What is 9 less than 322?
(A) 311 (B) 315 (C) 314 (D) 313 ✓
23. Which is shortest?
(A) 12 metres (B) 12 centimetres (C) 12 millimetres
(D) 12 kilometres ✓
24. Which is longest?
(A) 15 metres (B) 15 centimetres (C) 15 millimetres
(D) 15 kilometres
25. Which is heaviest?
(A) 12 grams (B) 12 centigrams (C) 12 milligrams
(D) 12 kilograms
26. Which is lightest?
(A) 11 grams (B) 11 centigrams (C) 11 milligrams
(D) 11 kilograms
27. How many €1 coins are there in €20?
(A) 40 (B) 20 (C) 10 (D) 60
28. How many €1 coins are there in €50?
(A) 10 (B) 20 (C) 30 (D) 50
29. How many 10 cent coins are there in €5?
(A) 100 (B) 50 (C) 500 (D) 150
30. How many 10 cent coins are there in €10?
(A) 1000 (B) 50 (C) 100 (D) 200 ✓
31. How many 5 cent coins are there in €5?
(A) 500 (B) 200 (C) 150 (D) 100 ✓
32. How many 5 cent coins are there in €10?
(A) 200 (B) 2000 (C) 100 (D) 150 ✓
33. How many €5 notes are there in €100?
(A) 20 (B) 40 (C) 50 (D) 60 ✓

34. How many €5 notes are there in €500?
(A) 1000 (B) 50 (C) 100 (D) 150
35. How many €5 notes are there in €200?
(A) 50 (B) 45 (C) 40 (D) 60
36. How many €5 notes are there in €300?
(A) 40 (B) 20 (C) 50 (D) 60
37. How many €5 notes are there in €400?
(A) 70 (B) 80 (C) 60 (D) 100
38. How many €5 notes are there in €600?
(A) 150 (B) 120 (C) 100 (D) 140
39. What is $44 + 7$?
(A) 55 (B) 53 (C) 51 (D) 52
40. What is $54 + 9$?
(A) 65 (B) 64 (C) 63 (D) 62
41. What is $74 + 9$?
(A) 85 (B) 84 (C) 83 (D) 86
42. What is $48 + 9$?
(A) 55 (B) 58 (C) 56 (D) 57
43. What is $94 + 9$?
(A) 113 (B) 102 (C) 103 (D) 104
44. What is $66 + 9$?
(A) 85 (B) 76 (C) 75 (D) 77 ✓
45. What is $93 + 9$?
(A) 102 (B) 103 (C) 104 (D) 105 ✓
46. What is $99 + 8$?
(A) 106 (B) 107 (C) 108 (D) 105 ✓
47. What is $97 + 9$?
(A) 109 (B) 116 (C) 106 (D) 107 ✓

48. What is $96 + 9$?
(A) 106 (B) 107 (C) 105 (D) 117
49. What is $93 + 9$?
(A) 101 (B) 102 (C) 104 (D) 105
50. What is $96 + 5$?
(A) 102 (B) 104 (C) 101 (D) 103
51. What is $96 + 8$?
(A) 104 (B) 103 (C) 105 (D) 106
52. What is $98 + 9$?
(A) 106 (B) 107 (C) 104 (D) 105
53. What is $92 + 9$?
(A) 101 (B) 102 (C) 111 (D) 103
54. What is $96 - 9$?
(A) 67 (B) 77 (C) 87 (D) 86
55. What is $66 - 9$?
(A) 57 (B) 55 (C) 47 (D) 56
56. What is $92 - 9$?
(A) 83 (B) 73 (C) 84 (D) 85
57. What is $56 - 9$?
(A) 46 (B) 37 (C) 47 (D) 45
58. What is $55 - 9$?
(A) 47 (B) 36 (C) 46 (D) 45
59. What is $38 - 9$?
(A) 29 (B) 19 (C) 28 (D) 27
60. What is $76 - 9$?
(A) 66 (B) 57 (C) 67 (D) 65
61. What is $77 - 8$?
(A) 68 (B) 59 (C) 67 (D) 69

62. What is $67 - 8$?
(A) 59 (B) 58 (C) 49 (D) 57
63. What is $72 - 8$?
(A) 63 (B) 64 (C) 65 (D) 54
64. What is $52 - 7$?
(A) 45 (B) 46 (C) 35 (D) 44
65. What is $72 - 5$?
(A) 66 (B) 67 (C) 57 (D) 63
66. What is $42 - 8$?
(A) 26 (B) 34 (C) 24 (D) 25
67. What is $44 - 6$?
(A) 26 (B) 38 (C) 28 (D) 29
68. What is $94 - 9$?
(A) 86 (B) 75 (C) 85 (D) 87
69. $4/6$ is equal to $2/ ?$
(A) 4 (B) 3 (C) 2 (D) 6 ✓
70. $8/6$ is equal to $4/ ?$
(A) 6 (B) 4 (C) 3 (D) 5 ✓
71. $4/8$ is equal to $2/ ?$
(A) 8 (B) 5 (C) 3 (D) 4 ✓
72. $4/10$ is equal to $2/ ?$
(A) 6 (B) 4 (C) 10 (D) 5 ✓
73. $8/16$ is equal to $2/ ?$
(A) 5 (B) 8 (C) 4 (D) 16
74. $6/8$ is equal to $3/ ?$
(A) 4 (B) 8 (C) 6 (D) 12
75. $9/12$ is equal to $3/ ?$
(A) 9 (B) 4 (C) 6 (D) 12

76. $12/16$ is equal to $3/ ?$
(A) 12 (B) 16 (C) 4 (D) 8
77. $1/2$ is the same as:
(A) 50% (B) 20% (C) 30% (D) 40%
78. $1/4$ is the same as:
(A) 20% (B) 25% (C) 40% (D) 5%
79. $1/5$ is the same as:
(A) 60% (B) 40% (C) 20% (D) 30%
80. $1/10$ is the same as:
(A) 30% (B) 20% (C) 40% (D) 10%
81. $1/8$ is the same as:
(A) 16% (B) 9% (C) $12\frac{1}{2}\%$ (D) 24%
82. What is 23×10 ?
(A) 330 (B) 2300 (C) 230 (D) 300
83. What is 73×10 ?
(A) 730 (B) 370 (C) 7700 (D) 7303
84. What is 86×10 ?
(A) 870 (B) 86 (C) 8600 (D) 860
85. What is 78×10 ?
(A) 78000 (B) 770 (C) 7800 (D) 780
86. What is 29×10 ?
(A) 2900 (B) 290 (C) 29 (D) 29000
87. What is 13×100 ?
(A) 130 (B) 13000 (C) 1300 (D) 2300
88. What is 93×100 ?
(A) 3900 (B) 930 (C) 93000 (D) 9300
89. What is 98×100 ?
(A) 8900 (B) 98000 (C) 9800 (D) 9900

90. What is 65×100 ?
(A) 5600 (B) 650 (C) 6500 (D) 65000
91. What is 58×100 ?
(A) 580 (B) 5800 (C) 58000 (D) 8500
92. What is 83×1000 ?
(A) 83000 (B) 38000 (C) 8300 (D) 830000
93. What is 96×1000 ?
(A) 9600 (B) 96000 (C) 960 (D) 69000
94. What is 92×1000 ?
(A) 92000 (B) 92000 (C) 9200 (D) 920
95. What is 15×1000 ?
(A) 150000 (B) 1500 (C) 15000 (D) 150
96. What is 68×1000 ?
(A) 68000 (B) 6800 (C) 680 (D) 86000
97. Which number will divide equally by 2 (with no remainder)?
(A) 26 (B) 33 (C) 37 (D) 75
98. Which number will divide equally by 4 (with no remainder)?
(A) 42 (B) 56 (C) 34 (D) 35
99. Which number will divide equally by 3 (with no remainder)?
(A) 35 (B) 36 (C) 37 (D) 31 ✓
100. Which number will divide equally by 7 (with no remainder)?
(A) 37 (B) 27 (C) 28 (D) 29 ✓
101. Which number will divide equally by 9 (with no remainder)?
(A) 47 ✓ (B) 19 (C) 28 (D) 36

102. Which number will divide equally by 8 (with no remainder)?
(A) 49 (B) 35 (C) 64 (D) 28 ✓
103. What is $\frac{1}{2}$ of 44?
(A) 88 (B) 24 (C) 23 (D) 22
104. What is $\frac{1}{2}$ of 34?
(A) 12 (B) 64 (C) 17 (D) 18
105. What is $\frac{1}{2}$ of 36?
(A) 16 (B) 72 (C) 17 (D) 18
106. What is $\frac{1}{2}$ of 38?
(A) 17 (B) 76 (C) 19 (D) 18
107. What is $\frac{1}{2}$ of 42?
(A) 84 (B) 21 (C) 31 (D) 22
108. What is $\frac{1}{2}$ of 48?
(A) 25 (B) 23 (C) 24 (D) 27
109. What is $\frac{1}{2}$ of 64?
(A) 33 (B) 128 (C) 32 (D) 34
110. How many even numbers are there between 3 and 19?
(A) 8 (B) 7 (C) 9 (D) 10
111. How many odd numbers are there between 2 and 22?
(A) 8 (B) 10 (C) 11 (D) 12
112. What is $44 + 9$?
(A) 47 (B) 44 (C) 37 (D) 53
113. What is $444 + 99$?
(A) 544 (B) 543 (C) 545 (D) 563
114. What is 7×8 ?
(A) 64 (B) 49 (C) 56 (D) 63
115. What is $24 - 13$?
(A) 13 (B) 10 (C) 12 (D) 11

116. What is $24 \div 6$?
 (A) 5 (B) 4 (C) 6 (D) 7
117. If a prize of €250 is divided equally between 5 winners how much does each winner get?
 (A) €50 (B) €60 (C) €55 (D) €40
118. Which is biggest?
 (A) $\frac{2}{3}$ (B) $\frac{1}{5}$ (C) $\frac{5}{6}$ (D) $\frac{2}{2}$
119. Pat scored 150 out of 300 in a test. What % is that?
 (A) 30% (B) 50% (C) 60% (D) 60%
120. What number is halfway between 30 and 42?
 (A) 36 (B) 35 (C) 37 (D) 34
121. $(15 + 5) \times 2 =$
 (A) 25 (B) 22 (C) 40 (D) 85
122. How many tens in 120?
 (A) 12 (B) 13 (C) 24 (D) 10
123. What is $\frac{4}{6}$ in its simplest form?
 (A) $\frac{2}{3}$ (B) $\frac{2}{6}$ (C) $\frac{6}{4}$ (D) 1
124. 1, 3, 6, 10, What number comes next?
 (A) 14 (B) 15 (C) 16 (D) 13
125. $\frac{60}{100} + \frac{4}{10} =$
 (A) 1 or $\frac{100}{100}$ (B) $\frac{64}{110}$
 (C) $\frac{64}{100}$ (D) $\frac{64}{10}$
126. A film begins at 7:25 p.m. and lasts for one hour and thirty minutes. What time does the film end?
 (A) 7:55 (B) 8:55 (C) 8:45 (D) 9:00
127. A train leaves Cork (Kent station) at 7:10 a.m. and takes two hours and forty-five minutes to reach Dublin. What time does the train arrive in Dublin (Heuston)?
 (A) 9:30 (B) 10:00 (C) 9:55 (D) 9:45

128. A pop concert begins at 10:55 p.m. and lasts for two hours and thirty-five minutes. What time does the concert end?
(A) 13:40 (B) 13:30 (C) 12:30 (D) 11:40

129. What is the average of 17, 18, 19?
(A) 19 (B) 18 (C) 17 (D) 54

130. What is the length of the perimeter of this square?

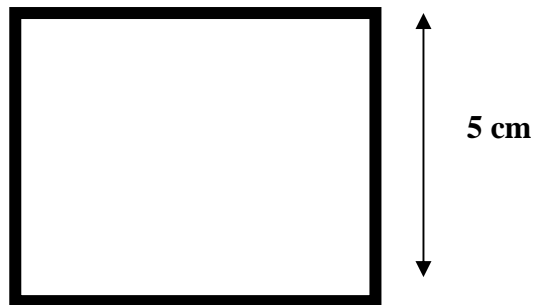

- (A) 10 cm (B) 20 cm (C) 15cm (D) 25 cm

131. What is the area of this square?

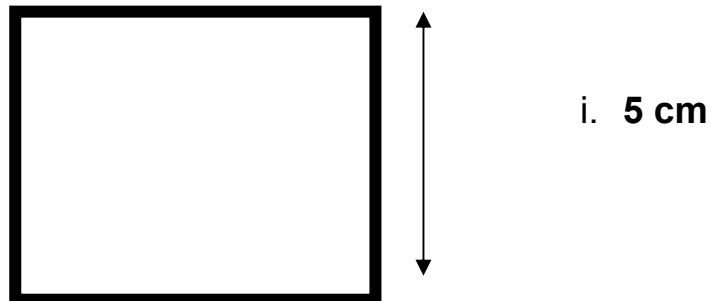

- (A) 25 cm² (B) 20 cm² (C) 35 cm² (D) 15 cm²

132. What is the length of the perimeter of this rectangle?

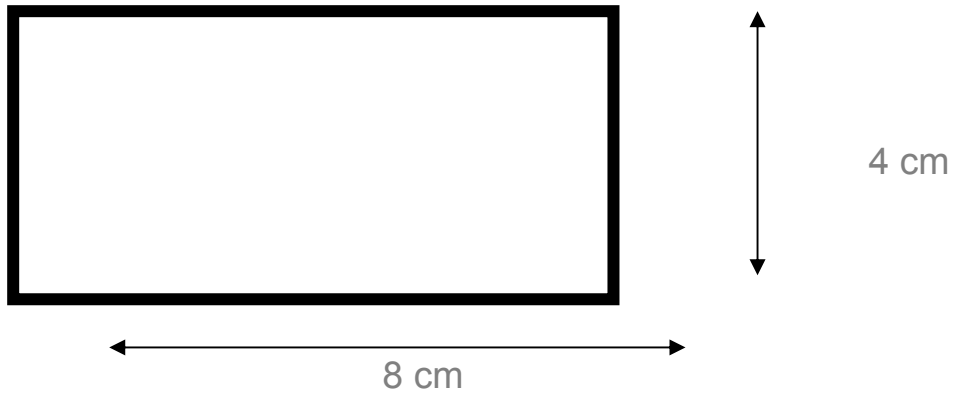

- (A) 24 cm (B) 20 cm (C) 16 cm (D) 28 cm

133. What is the area of this rectangle?

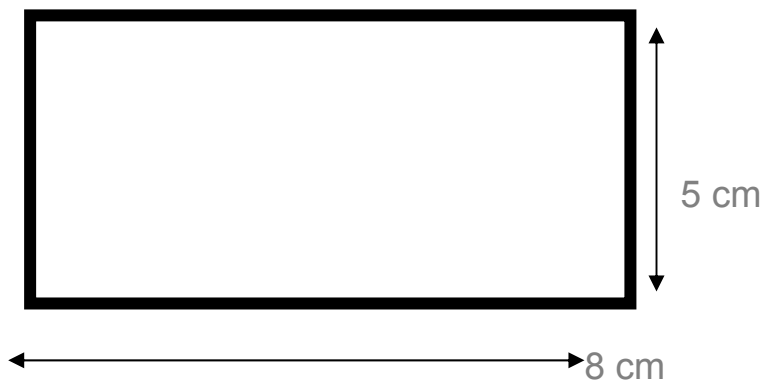

- (A) 18 cm² (B) 40 cm² (C) 26 cm² (D) 23 cm²

134. What is the volume of this cube?

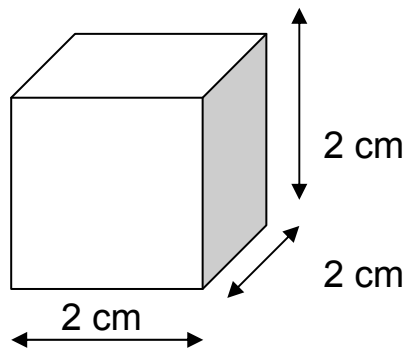

- (A) 6 cm³ (B) 8 cm³ (C) 10 cm³ (D) 4 cm³

Category 2:

2,000 Point Questions
5,000 Point Questions
10,000 Point Questions
20,000 Point Questions
50,000 Point Questions

1. What is $44 + 26$?
(A) 60 (B) 70 (C) 80 (D) 80
2. What is $54 + 36$?
(A) 80 (B) 70 (C) 90 (D) 60
3. What is $42 + 26$?
(A) 58 (B) 78 (C) 64 (D) 68
4. What is $43 + 27$?
(A) 60 (B) 70 (C) 80 (D) 90
5. What is $83 + 17$?
(A) 90 (B) 100 (C) 110 (D) 99
6. What is $88 + 27$?
(A) 115 (B) 125 (C) 105 (D) 145
7. What is $43 + 67$?
(A) 110 (B) 120 (C) 130 (D) 90
8. What is $53 + 28$?
(A) 71 (B) 101 (C) 81 (D) 91
9. What is $73 + 17$?
(A) 91 (B) 100 (C) 90 (D) 80
10. What is $93 + 27$?
(A) 120 (B) 110 (C) 130 (D) 100
11. What is $48 + 24$?
(A) 62 (B) 72 (C) 82 (D) 92
12. What is $49 + 27$?
(A) 76 (B) 86 (C) 96 (D) 66 ✓

13. What is $42 + 64$?
(A) 126 (B) 96 (C) 106 (D) 116 ✓
14. What is $88 + 24$?
(A) 102 (B) 92 (C) 122 (D) 112 ✓
15. What is $47 + 26$?
(A) 73 (B) 83 (C) 93 (D) 63 ✓
16. What is $82 + 64$?
(A) 156 (B) 146 (C) 136 (D) 126
17. What is $49 + 33$?
(A) 92 (B) 82 (C) 72 (D) 102
18. What is $98 + 44$?
(A) 132 (B) 142 (C) 122 (D) 152
19. What is $77 + 66$?
(A) 123 (B) 153 (C) 133 (D) 143
20. What is $95 + 57$?
(A) 152 (B) 162 (C) 142 (D) 132
21. What is $49 + 66$?
(A) 125 (B) 115 (C) 95 (D) 135
22. What is $68 - 24$?
(A) 44 (B) 34 (C) 54 (D) 64
23. What is $97 - 26$?
(A) 51 (B) 61 (C) 81 (D) 71
24. What is $73 - 27$?
(A) 46 (B) 56 (C) 66 (D) 36
25. What is $63 - 17$?
(A) 46 (B) 56 (C) 36 (D) 66
26. What is $48 - 27$?
(A) 12 (B) 31 (C) 11 (D) 21 ✓

27. What is $93 - 67$?
(A) 37 (B) 24 (C) 27 (D) 26 ✓
28. What is $63 - 28$?
(A) 36 (B) 35 (C) 34 (D) 45 ✓
29. What is $53 - 17$?
(A) 36 (B) 35 (C) 46 (D) 34 ✓
30. What is $73 - 27$?
(A) 47 (B) 45 (C) 46 (D) 56
31. What is $88 - 24$?
(A) 74 (B) 54 (C) 63 (D) 64
32. What is $79 - 27$?
(A) 42 (B) 52 (C) 62 (D) 72
33. What is $82 - 64$?
(A) 22 (B) 18 (C) 28 (D) 19
34. What is $88 - 24$?
(A) 64 (B) 74 (C) 54 (D) 44
35. What is $47 - 26$?
(A) 29 (B) 11 (C) 21 (D) 31
36. What is $82 - 54$?
(A) 32 (B) 18 (C) 38 (D) 28
37. What is $79 - 33$?
(A) 46 (B) 36 (C) 56 (D) 34 ✓
38. What is $88 - 44$?
(A) 24 (B) 44 (C) 34 (D) 54 ✓
39. What is $97 - 66$?
(A) 21 (B) 31 (C) 41 (D) 24 ✓
40. What is $95 - 57$?
(A) 32 (B) 28 (C) 38 (D) 48

41. What is $99 - 66$?
(A) 33 (B) 43 (C) 23 (D) 53
42. Which is the heaviest?
(A) 5·4 kg (B) 54kg (C) 4·5 kg (D) 45 kg ✓
43. Which is the lightest?
(A) 7·4 g (B) 3·7 g (C) 73 g (D) 37 g
44. What is $1300 \div 100$?
(A) 130 (B) 13 (C) 1·3 (D) 1300
45. What is $9300 \div 100$?
(A) 9·3 (B) 930 (C) 93 (D) 9300
46. What is $9800 \div 100$?
(A) 980 (B) 98000 (C) 98 (D) 9·8
47. What is $6500 \div 100$?
(A) 65 (B) 6500 (C) 650 (D) 6·5
48. What is $5800 \div 100$?
(A) 5800 (B) 58 (C) 5·8 (D) 580
49. What is $8300 \div 100$?
(A) 83 (B) 83000 (C) 8·3 (D) 830
50. What is $9600 \div 100$?
(A) 960 (B) 9600 (C) 96 (D) 9·6
51. What is $9200 \div 100$?
(A) 29 (B) 9·2 (C) 92 (D) 290

52. What is $1500 \div 100$?

- (A) 150 (B) 1·5 (C) 15 (D) 51

53. What is $6800 \div 100$?

- (A) 680 (B) 86 (C) 68 (D) 6·8

54. How much does a pack of 10 biros cost when each biro is 25 cents?

- (A) 25000 cents (B) 2500 cents
(C) 250 cents (D) 25 cents

55. How much does a pack of 15 biros cost when each biro is 20 cents?

- (A) 30 cents (B) 3000 cents
(C) 300 cents (D) 30000 cents

56. How much does a pack of 12 biros cost when each biro is 15 cents?

- (A) 170 cents (B) 18000 cents
(C) 180 cents (D) 330 cents

57. How much does a pack of 10 biros cost when each biro is 32 cents?

- (A) 32000 cents (B) 320 cents
(C) 3200 cents (D) 2300 cents



58. How much does a pack of 15 biros cost when each biro is 30 cents?

- (A) 5400 cents (B) 4500 cents
(C) 450 cents (D) 54000 cents

59. What is the missing number: 225, 230,....., 240, 245 ? \checkmark

- (A) 236 (B) 255 (C) 235 (D) 237

60. What is the missing number: 220, 226,....., 238, 244 ?

- (A) 235 (B) 234 (C) 230 (D) 232

61. What is the missing number: 20, 40,....., 80, 100 ?
(A) 70 (B) 60 (C) 50 (D) 55
62. What is the missing number: 27,....., 47, 57 ?
(A) 35 (B) 37 (C) 38 (D) 36
63. What is the missing number: 77, 66,....., 44, 33 ?
(A) 54 (B) 55 (C) 50 (D) 56
64. Which number will divide equally by 9 (with no remainder)?
(A) 48 (B) 45 (C) 46 (D) 47 ✓
65. Which number will divide equally by 8 (with no remainder)?
(A) 41 (B) 38 (C) 40 (D) 42
66. Which number will divide equally by 7 (with no remainder)?
(A) 49 (B) 48 (C) 46 (D) 44
67. What is $\frac{1}{3}$ of 24?
(A) 12 (B) 7 (C) 8 (D) 9
68. What is $\frac{1}{3}$ of 27?
(A) 12 (B) 6 (C) 8 (D) 9 ✓
69. What is $\frac{1}{3}$ of 33?
(A) 9 (B) 13 (C) 11 (D) 12
70. What is $\frac{1}{3}$ of 36?
(A) 14 (B) 11 (C) 12 (D) 13
71. What is $\frac{1}{3}$ of 39?
(A) 16 (B) 15 (C) 13 (D) 14
72. What is $\frac{1}{3}$ of 42?
(A) 12 (B) 15 (C) 14 (D) 11
73. How many even numbers are there between 31 and 43?
(A) 5 (B) 6 (C) 7 (D) 8

74. How many odd numbers are there between 22 and 32?
(A) 6 (B) 5 (C) 7 (D) 8
75. $42 = 10 \times 4$ and a remainder of ...
(A) 4 (B) 2 (C) 3 (D) 5
76. **64** = 10×6 and a remainder of....
(A) 4 (B) 6 (C) 7 (D) 8
77. $72 = 10 \times 7$ and a remainder of...
(A) 2 (B) 3 (C) 4 (D) 5
78. $95 = 10 \times 9$ and a remainder of...
(A) 7 (B) 6 (C) 5 (D) 4
79. **86** = 10×8 and a remainder of...
(A) 5 (B) 6 (C) 8 (D) 9
80. $92 = 10 \times 9$ and a remainder of...
(A) 2 (B) 3 (C) 4 (D) 5
81. **98** = 10×9 and a remainder of...
(A) 9 (B) 8 (C) 7 (D) 6
82. $87 = 10 \times 8$ and a remainder of...
(A) 6 (B) 7 (C) 5 (D) 4
83. The match began at 2:00pm. The teams played 45 minutes in each half. The half-time break was 10 minutes. When did the match finish?
(A) 3:50 (B) 3:40
(C) 3:30 (D) 3:20 ✓
84. The match began at 4:00pm. The teams played 40 minutes in each half. The half-time break was 10 minutes. When did the match finish?
(A) 5:30 (B) 5:40
(C) 5:20 (D) 5:50

85. The match began at 3:00pm. The teams played 30 minutes in each half. The half-time break was 10 minutes. When did the match finish?
- (A) 4:30 (B) 4:40
(C) 4:10 (D) 4:20
86. Patricia got up at 8:00am. She left home 20 minutes later. She arrived at school at 8:40am. How long did his journey to school take?
- (A) 20 minutes (B) 40 minutes
(C) 10 minutes (D) 30 minutes ✓
87. Mary got up at 8:00am. She left home 20 minutes later. She arrived at school at 8:45am. How long did his journey to school take?
- (A) 30 minutes (B) 25 minutes
(C) 40 minutes (D) 10 minutes
88. Patricia got up at 8:00am. She left home 10 minutes later. She arrived at school at 8:50am. How long did his journey to school take?
- (A) 40 minutes (B) 30 minutes
(C) 20 minutes (D) 50 minutes
89. Which is the largest fraction?
(A) $\frac{1}{10}$ (B) $\frac{5}{10}$ (C) $\frac{7}{10}$ (D) $\frac{10}{10}$ ✓
90. Which is the largest fraction?
(A) $\frac{1}{7}$ (B) $\frac{6}{7}$ (C) $\frac{2}{7}$ (D) $\frac{7}{7}$
91. Which is the smallest fraction?
(A) $\frac{5}{10}$ (B) $\frac{4}{10}$ (C) $\frac{7}{10}$ (D) $\frac{10}{10}$ ✓
92. Which is the smallest fraction?
(A) $\frac{1}{7}$ (B) $\frac{4}{7}$ (C) $\frac{2}{7}$ (D) $\frac{9}{7}$
93. $\frac{6}{4} + \frac{5}{4} =$
(A) $\frac{1}{4}$ (B) $\frac{11}{4}$ (C) $\frac{11}{8}$ (D) $\frac{30}{16}$

94. $\frac{3}{4} + \frac{2}{4} =$
(A) $\frac{5}{16}$ (B) $\frac{32}{44}$ (C) $\frac{5}{4}$ (D) $\frac{6}{4}$
95. $\frac{7}{4} + \frac{1}{4} =$
(A) $\frac{8}{4}$ (B) $\frac{6}{4}$ (C) $\frac{71}{44}$ (D) $\frac{8}{8}$
96. $\frac{6}{9} + \frac{5}{9} =$
(A) $\frac{11}{9}$ (B) $\frac{30}{81}$ (C) $\frac{1}{0}$ (D) $\frac{11}{18}$
97. $\frac{1}{3} + \frac{5}{3} =$
(A) $\frac{6}{6}$ (B) $\frac{6}{3}$ (C) $\frac{30}{9}$ (D) $\frac{6}{9}$
98. $\frac{6}{4} - \frac{3}{4} =$
(A) $\frac{18}{16}$ (B) $\frac{3}{8}$ (C) $\frac{3}{4}$ (D) $\frac{3}{0}$
99. $\frac{7}{4} - \frac{1}{4} =$
(A) $\frac{6}{4}$ (B) $\frac{6}{0}$ (C) $\frac{7}{16}$ (D) $\frac{8}{8}$
100. $\frac{8}{5} - \frac{3}{5} =$
(A) $\frac{5}{0}$ (B) $\frac{5}{5}$ (C) $\frac{24}{25}$ (D) $\frac{13}{5}$
101. How many halves in 1?
(A) 2 (B) $\frac{1}{2}$ (C) 4 (D) 6
102. How many halves in 2?
(A) 2 (B) 4 (C) 8 (D) 16
103. How many halves in 4?
(A) 8 (B) 10 (C) 2 (D) 16
104. How many thirds in 1?
(A) $\frac{1}{3}$ (B) 9 (C) 3 (D) 6
105. How many thirds in 2?
(A) 8 (B) $\frac{2}{3}$ (C) 9 (D) 6
106. How many thirds in 3?
(A) 3 (B) 6 (C) 9 (D) 12
107. How many quarters in 1?
(A) $\frac{1}{4}$ (B) 4 (C) 16 (D) 8 ✓

108. How many quarters in 2?
(A) 10 (B) 6 (C) 8 (D) $\frac{2}{4}$ ✓
109. How many quarters in 3?
(A) $\frac{3}{4}$ (B) $\frac{4}{3}$ (C) 9 (D) 12
110. How many fifths in 1?
(A) 6 (B) 5 (C) $\frac{1}{5}$ (D) 25 ✓
111. How many fifths in 2?
(A) $\frac{2}{5}$ (B) 10 (C) $\frac{5}{2}$ (D) 20
112. How many fifths in 3?
(A) $\frac{3}{5}$ (B) 15 (C) $\frac{5}{3}$ (D) 25 ✓

Category 3:

75,000 Point Questions
150,000 Point Questions
250,000 Point Questions

1. What is $45 + 25 + 1$?
(A) 61 (B) 51 (C) 71 (D) 81
2. What is $52 + 38 + 2$?
(A) 72 (B) 82 (C) 102 (D) 92
3. What is $43 + 27 + 9$?
(A) 69 (B) 79 (C) 89 (D) 99
4. What is $23 + 27 + 8$?
(A) 48 (B) 58 (C) 68 (D) 78
5. What is $73 + 17 + 8$?
(A) 98 (B) 88 (C) 108 (D) 78
6. What is $68 + 22 + 6$?
(A) 96 (B) 106 (C) 86 (D) 76
7. What is $53 + 27 + 7$?
(A) 77 (B) 67 (C) 87 (D) 97 ✓
8. What is $57 + 23 + 5$?
(A) 85 (B) 65 (C) 75 (D) 105
9. What is $33 + 17 + 7$?
(A) 77 (B) 67 (C) 57 (D) 87 ✓
10. What is $83 + 27 + 6$?
(A) 96 (B) 116 (C) 126 (D) 136 ✓
11. What is $58 + 22 + 5$?
(A) 75 (B) 65 (C) 85 (D) 95 ✓
12. What is $29 + 21 + 5$?
(A) 65 (B) 55 (C) 45 (D) 85

13. What is $42 + 68 + 3$?
(A) 113 (B) 114 (C) 115 (D) 116 ✓
14. What is $68 + 22 + 4$?
(A) 84 (B) 94 (C) 104 (D) 114 ✓
15. What is $57 + 23 + 5$?
(A) 75 (B) 65 (C) 85 (D) 55 ✓
16. What is $52 + 68 + 2$?
(A) 122 (B) 112 (C) 92 (D) 123 ✓
17. What is $29 + 31 + 6$?
(A) 56 (B) 46 (C) 66 (D) 76
18. What is $68 + 42 + 9$?
(A) 117 (B) 99 (C) 109 (D) 119
19. What is $67 + 63 + 4$?
(A) 124 (B) 144 (C) 134 (D) 104
20. What is $55 + 55 + 8$?
(A) 118 (B) 98 (C) 108 (D) 128
21. What is $29 + 61 + 9$?
(A) 89 (B) 109 (C) 99 (D) 119
22. What is $622 - 23$?
(A) 499 (B) 599 (C) 699 (D) 399
23. What is $923 - 24$?
(A) 699 (B) 799 (C) 899 (D) 599
24. What is $711 - 12$?
(A) 399 (B) 499 (C) 599 (D) 699
25. What is $624 - 25$?
(A) 599 (B) 699 (C) 499 (D) 399
26. What is $481 - 82$?
(A) 299 (B) 399 (C) 499 (D) 199

27. What is $913 - 14$?
(A) 799 (B) 699 (C) 899 (D) 599
28. What is $623 - 24$?
(A) 499 (B) 599 (C) 399 (D) 699
29. What is $533 - 34$?
(A) 499 (B) 599 (C) 699 (D) 399
30. What is $713 - 14$?
(A) 899 (B) 499 (C) 599 (D) 699
31. What is $838 - 39$?
(A) 699 (B) 799 (C) 599 (D) 499
32. What is $719 - 20$?
(A) 499 (B) 599 (C) 299 (D) 699
33. What is $852 - 53$?
(A) 699 (B) 599 (C) 799 (D) 499
34. What is $828 - 29$?
(A) 699 (B) 599 (C) 799 (D) 499
35. What is $447 - 48$?
(A) 299 (B) 399 (C) 499 (D) 199
36. What is $122 - 23$?
(A) 99 (B) 119 (C) 89 (D) 79
37. What is $229 - 30$?
(A) 189 (B) 199 (C) 179 (D) 169
38. What is $328 - 29$?
(A) 279 (B) 289 (C) 299 (D) 269
39. What is $537 - 38$?
(A) 489 (B) 499 (C) 479 (D) 469
40. What is $215 - 16$?
(A) 199 (B) 189 (C) 179 (D) 159 ✓

41. What is $229 - 30$?
(A) 189 (B) 179 (C) 169 (D) 199 ✓
42. If today is Wednesday the 15th, what date will next Friday be?
(A) 19th (B) 16th (C) 17th (D) 18th ✓
43. If today is Wednesday the 10th, what date was last Monday?
(A) 7th (B) 8th (C) 6th (D) 5th ✓
44. If today is Wednesday the 12th, what date will next Sunday be?
(A) 14th (B) 17th (C) 16th (D) 15th ✓
45. If today is Wednesday the 9th, what date was last Sunday?
(A) 5th (B) 6th (C) 7th (D) 4th
46. If today is Wednesday the 12th, what date will next Wednesday be?
(A) 16th (B) 18th (C) 19th (D) 17th
47. If today is Wednesday the 10th, what date was last Saturday?
(A) 5th (B) 6th (C) 4th (D) 7th
48. $\frac{1}{2}$ is the same as:
(A) $\cdot 6$ (B) $\cdot 5$ (C) $\cdot 12$ (D) $\cdot 25$
49. $\frac{1}{4}$ is the same as:
(A) $\cdot 25$ (B) $\cdot 35$ (C) $\cdot 14$ (D) $\cdot 025$
50. $\frac{1}{5}$ is the same as:
(A) $\cdot 2$ (B) $\cdot 25$ (C) $\cdot 3$ (D) $\cdot 15$
51. $\frac{1}{10}$ is the same as:
(A) $\cdot 1$ (B) $\cdot 01$ (C) $\cdot 20$ (D) $\cdot 25$
52. $\frac{1}{5}$ is the same as:
(A) $\cdot 2$ (B) $\cdot 25$ (C) $\cdot 15$ (D) $\cdot 51$

53. $\frac{1}{8}$ is the same as:
(A) $\cdot 18$ (B) $\cdot 125$ (C) $\cdot 81$ (D) $\cdot 25$
54. $\frac{1}{2}$ is the same as:
(A) 20% (B) 50% (C) 30% (D) 12%
55. $\frac{1}{4}$ is the same as:
(A) 50% (B) 25% (C) 60% (D) 14%
56. $\frac{1}{5}$ is the same as:
(A) 20% (B) 6% (C) 15% (D) 25% ✓
57. $\frac{1}{10}$ is the same as:
(A) 100% (B) 50% (C) 25% (D) 10% ✓
58. $\frac{2}{5}$ is the same as:
(A) 7% (B) 40% (C) 10% (D) 25% ✓
59. $\frac{1}{8}$ is the same as:
(A) 10% (B) 80% (C) 12.5% (D) 18% ✓
60. What is the cost of 10 magazines if 100 cost €80?
(A) €10 (B) €8 (C) €18 (D) €40
61. What is the cost of 5 magazines if 100 cost €40?
(A) €4 (B) €2 (C) €6 (D) €8
62. What is the cost of 5 magazines if 100 cost €120?
(A) €4 (B) €6 (C) €2 (D) €8
63. What is the cost of 12 magazines if 36 cost €90?
(A) €20 (B) €30 (C) €15 (D) €45 ✓
64. What is the cost of 6 magazines if 18 cost €60?
(A) €30 (B) €35 (C) €25 (D) €20 ✓
65. Round 542 to the nearest 10
(A) 540 (B) 530 (C) 520 (D) 550
66. Round 654 to the nearest 10
(A) 650 (B) 660 (C) 670 (D) 640

67. Round 562 to the nearest 10
(A) 570 (B) 560 (C) 550 (D) 540
68. Round 762 to the nearest 10
(A) 760 (B) 770 (C) 780 (D) 750
69. Round 943 to the nearest 10
(A) 940 (B) 950 (C) 960 (D) 930
70. Round 1:45pm to the nearest hour
(A) 3:00pm (B) 2:00pm
(C) 4:00pm (D) 2:30pm
71. Round 1:35pm to the nearest hour
(A) 2:00pm (B) 3:00pm
(C) 4:00pm (D) 1:30pm ✓
72. Round 5:25pm to the nearest hour
(A) 4:00pm (B) 6:00pm
(C) 5:00pm (D) 5:30pm ✓
73. Round 3:55pm to the nearest hour
(A) 4:00pm (B) 2:00pm
(C) 5:00pm (D) 3:30pm
74. Round 12:53pm to the nearest hour
(A) 15:00pm (B) 13:00pm
(C) 14:00pm (D) 12:30pm
75. Round 9:48pm to the nearest hour
(A) 12:00pm (B) 11:00pm
(C) 10:00pm (D) 9:30pm
76. Round 17:41pm to the nearest hour
(A) 18:00pm (B) 19:00pm
(C) 20:00pm (D) 17:30pm
77. Round 66km to the nearest 10km
(A) 50km (B) 80km
(C) 70km (D) 90km

78. Round 62 to the nearest 10 km
(A) 50km (B) 65km
(C) 60km (D) 70km
79. Round 76 to the nearest 10 km
(A) 50km (B) 80km
(C) 70km (D) 90km
80. Round 94 to the nearest 10 km
(A) 100km (B) 110km
(C) 70km (D) 90km
81. Round 66 to the nearest 10 km
(A) 50km (B) 80km
(C) 70km (D) 90km
82. Round 62 to the nearest 10 km
(A) 50km (B) 60km
(C) 70km (D) 80km
83. Round 762 to the nearest 100 km
(A) 700km (B) 800km
(C) 900km (D) 500km
84. Round 343 to the nearest 100 km
(A) 200km (B) 300km
(C) 400km (D) 500km
85. Round 76km to the nearest 100 km
(A) 100km (B) 300km
(C) 400km (D) 200km
86. Round 86km to the nearest 100 km
(A) 100km (B) 50km
(C) 200km (D) 8600km
87. Round 144km to the nearest 100 km
(A) 100km (B) 200km
(C) 250km (D) 300km

88. "30 days has September, April, June and November
All the rest have 31, except February alone. And that
has 28 days clear and 29 in each leap year".

What is the combined total of days in July and May?

- (A) 60 (B) 62 (C) 61 (D) 63

89. "30 days has September, April, June and November
All the rest have 31, except February alone
And that has 28 days clear and 29 in each leap year".

What is the combined total of days in April and
September?

- (A) 61 (B) 62 (C) 60 (D) 64

90. "30 days has September, April, June and November
All the rest have 31, except February alone. And that
has 28 days clear and 29 in each leap year".

What is the combined total of days in December and
July?

- (A) 61 (B) 64 (C) 63 (D) 62

91. $(6 \times 4) + ? = 29$

- (A) 3 (B) 4 (C) 5 (D) 6 ✓

92. $(12 \times 5) + ? = 79$

- (A) 9 (B) 19 (C) 29 (D) 39

93. $(15 \times 4) + ? = 99$

- (A) 19 (B) 49 (C) 39 (D) 29

94. $(16 \times 3) + ? = 89$

- (A) 41 (B) 51 (C) 31 (D) 61

95. $(12 \times 6) + ? = 99$

- (A) 47 (B) 17 (C) 27 (D) 37

96. $(16 \times 4) + ? = 88$

- (A) 44 (B) 14 (C) 34 (D) 24

97. I buy 2 boxes of chocolates at € 5.50 each. What was my change from €20
(A) €11 (B) €9 (C) €7 (D) €8
98. I buy 4 boxes of chocolates at € 5.50 each. What was my change from €30?
(A) €8 (B) €9 (C) €6 (D) €7
99. A bottle contains 2 litres of coke. A full glass holds $\frac{1}{3}$ of a litre. How many full glasses can be filled from the coke bottle?
(A) 16 (B) 4 (C) 6 (D) 12
100. A bottle contains 1 litre of orange. A full glass holds $\frac{1}{5}$ of a litre. How many full glasses can be filled from the orange bottle?
(A) 10 (B) 4 (C) 6 (D) 5
101. What is 50% of 100?
(A) 100 (B) 50 (C) 40 (D) 25 ✓
102. What is 50% of 200?
(A) 100 (B) 50 (C) 400 (D) 25
103. What is 50% of 16?
(A) 10 (B) 8 (C) 80 (D) 16
104. What is 50% of 20?
(A) 100 (B) 50 (C) 10 (D) 25
105. What is 100% of 70?
(A) 170 (B) 70 (C) 30 (D) 35
106. What is 25% of 100?
(A) 125 (B) 50 (C) 4 (D) 25
107. What is 25% of 16?
(A) 100 (B) 44 (C) 40 (D) 4
108. What is 25% of 20?
(A) 500 (B) 5 (C) 45 (D) 25 ✓

109. What is 25% of 28?
(A) 280 (B) 77 (C) 70 (D) 7
110. What is 10% of 100?
(A) 100 (B) 110 (C) 10 (D) 25
111. What is 10% of 50?
(A) 5 (B) 50 (C) 40 (D) 1500 ✓

Category 4:

500,000 Point Questions
1,000,000 Point Questions

1. $131 + ? = 300$
(A) 159 (B) 169 (C) 179 (D) 189
2. $171 + ? = 300$
(A) 159 (B) 129 (C) 139 (D) 149
3. $182 + ? = 250$
(A) 68 (B) 78 (C) 88 (D) 98
4. $151 + ? = 350$
(A) 169 (B) 179 (C) 199 (D) 189 ✓
5. $201 + ? = 370$
(A) 159 (B) 189 (C) 169 (D) 179 ✓
6. $815 + ? = 960$
(A) 175 (B) 145 (C) 155 (D) 165 ✓
7. $416 + ? = 800$
(A) 454 (B) 364 (C) 384 (D) 394 ✓
8. $385 + ? = 700$
(A) 335 (B) 315 (C) 325 (D) 305
9. $438 + ? = 850$
(A) 432 (B) 402 (C) 412 (D) 422
10. $827 + ? = 900$
(A) 73 (B) 83 (C) 93 (D) 103
11. $416 + ? = 900$
(A) 474 (B) 464 (C) 484 (D) 494
12. What is $13 + 27 + 6$?
(A) 66 (B) 56 (C) 46 (D) 36

13. What is $28 + 24 + 5$?
(A) 37 (B) 47 (C) 57 (D) 67
14. What is $29 + 27 + 5$?
(A) 61 (B) 51 (C) 41 (D) 71
15. What is $32 + 24 + 3$?
(A) 79 (B) 59 (C) 69 (D) 49
16. What is $18 + 24 + 4$?
(A) 66 (B) 56 (C) 46 (D) 36
17. What is $27 + 26 + 5$?
(A) 48 (B) 58 (C) 68 (D) 78
18. What is $22 + 34 + 2$?
(A) 88 (B) 58 (C) 68 (D) 78 ✓
19. What is $24 + 33 + 6$?
(A) 43 (B) 53 (C) 73 (D) 63 ✓
20. What is $18 + 24 + 9$?
(A) 81 (B) 71 (C) 61 (D) 51 ✓
21. What is $17 + 16 + 4$?
(A) 37 (B) 47 (C) 57 (D) 67 ✓
22. What is $25 + 27 + 8$?
(A) 80 (B) 40 (C) 60 (D) 70
23. What is $19 + 26 + 9$?
(A) 64 (B) 54 (C) 44 (D) 34
24. If today is Wednesday the 12th, what day was the 7th?
(A) Friday (B) Saturday
(C) Sunday (D) Thursday
25. If today is Saturday the 18th, what day was the 7th?
(A) Friday (B) Saturday
(C) Sunday (D) Tuesday

26. If today is Sunday the 18th, what day was the 9th?
(A) Friday (B) Saturday
(C) Sunday (D) Thursday
27. If today is Monday the 18th, what day will the 27th be?
(A) Friday (B) Saturday
(C) Wednesday (D) Thursday
28. If today is Tuesday the 12th, what day will the 29th be?
(A) Friday (B) Saturday
(C) Sunday (D) Thursday
29. $\frac{3}{2}$ is the same as:
(A) 2·5 (B) 1·5 (C) 2·3 (D) 3·2
30. $\frac{5}{4}$ is the same as:
(A) 1·25 (B) 1·35 (C) 1·55 (D) 1·54 ✓
31. $\frac{3}{5}$ is the same as:
(A) ·7 (B) ·6 (C) ·8 (D) 3·5 ✓
32. $\frac{7}{10}$ is the same as:
(A) ·7 (B) ·8 (C) ·710 (D) ·107 ✓
33. $\frac{9}{5}$ is the same as:
(A) 9·5 (B) 1·8 (C) 1·4 (D) 5·9 ✓
34. $\frac{7}{8}$ is the same as:
(A) ·75 (B) ·87 (C) ·78 (D) ·875
35. $\frac{3}{2}$ is the same as:
(A) 250% (B) 132% (C) 123% (D) 150%
36. $\frac{5}{4}$ is the same as:
(A) 125% (B) 120% (C) 130% (D) 150%
37. $\frac{3}{5}$ is the same as:
(A) 50% (B) 60% (C) 135% (D) 70%
38. $\frac{7}{10}$ is the same as:
(A) 710% (B) 75% (C) 70% (D) 140%

39. $\frac{9}{5}$ is the same as:
(A) 295% (B) 180% (C) 170% (D) 150%
40. $\frac{4}{8}$ is the same as:
(A) 0.25 (B) 0.5 (C) 0.48 (D) 0.55
41. $\frac{3}{2}$ is the same as:
(A) 1.25 (B) 1.5 (C) 0.5 (D) 0.6
42. $\frac{7}{8}$ is the same as:
(A) 87.5% (B) 87% (C) 78% (D) 0.5%
43. How many sides in a pentagon?
(A) 4 (B) 5 (C) 4 (D) 6
44. How many sides in an octagon?
(A) 3 (B) 6 (C) 8 (D) 12 ✓
45. What is the nearest whole number to 5.7?
(A) 7.5 (B) 5.8 (C) 6 (D) 5
46. What is the nearest whole number to 52.6?
(A) 52.6 (B) 52.7 (C) 52 (D) 53
47. What is the nearest whole number to 11.4?
(A) 11 (B) 12 (C) 11.5 (D) 114
48. What is the nearest whole number to 9.9?
(A) 99 (B) 9.8 (C) 10 (D) 11
49. Round 654 to the nearest 100
(A) 650 (B) 700 (C) 600 (D) 500
50. Round 562 to the nearest 100
(A) 550 (B) 700 (C) 600 (D) 500 ✓
51. Round 762 to the nearest 100
(A) 760 (B) 800 (C) 600 (D) 700 ✓
52. Round 943 to the nearest 100
(A) 950 (B) 1000 (C) 800 (D) 900 ✓

**53. “30 days has September, April, June and November
All the rest have 31, except February alone. And that
has 28 days clear and 29 in each leap year”.**

**What is the combined total of days in *July, August* and
May?**

- (A) 92 (B) 90 (C) 92 (D) 93**



**54. “30 days has September, April, June and November
All the rest have 31, except February alone. And that
has 28 days clear and 29 in each leap year”.**

**What is the combined total of days in *December,*
October and *May*?**

- (A) 92 (B) 90 (C) 92 (D) 93**

**55. “30 days has September, April, June and November
All the rest have 31, except February alone. And that
has 28 days clear and 29 in each leap year”.**

**What is the combined total of days in *January, July* and
August?**

- (A) 92 (B) 90 (C) 92 (D) 93**

**56. “30 days has September, April, June and November
All the rest have 31, except February alone. And that
has 28 days clear and 29 in each leap year”.**

**What is the combined total of days in *July, November*
and leap year *February*?**

- (A) 92 (B) 90 (C) 92 (D) 93**

**57. Which number will divide equally by 12 (with no
remainder)?**

- (A) 42 (B) 36 (C) 37 (D) 38**

**58. Which number will divide equally by 11 (with no
remainder)?**

- (A) 33 (B) 36 (C) 37 (D) 36**

59. Which number will divide equally by 13 (with no remainder)?
 (A) 39 (B) 49 (C) 37 (D) 36
60. The product of 7 and 12 is
 (A) $7/12$ (B) 84 (C) 19 (D) 5
61. The product of 9 and 12 is
 (A) $9/12$ (B) 3 (C) 108 (D) 21
62. The product of 10 and 12 is
 (A) 22 (B) $10/12$ (C) 2 (D) 120
63. The product of 11 and 12 is
 (A) 1 (B) $11/12$ (C) 132 (D) 23
64. The product of 12 and 12 is
 (A) $12/24$ (B) $12/12$ (C) 24 (D) 144
65. The value of π (pi) is:
 (A) $2/3$ (B) $1/7$ (C) $22/7$ (D) $7/22$
66. What is the missing number in the sequence?
 0•2 0•4 ? 0•8
 (A) 0•6 (B) 0•5 (C) 0•7 (D) 0•10
67. What is the missing number in the sequence?
 2•3 2•1 ? 1•7
 (A) 1•8 (B) 1•9 (C) 1•7 (D) 2•0
68. What is the missing number in the sequence?
 -3 -5 ? -9
 (A) -7 (B) -6 (C) -8 (D) -8.5
69. What is the missing number in the sequence?
 -5 -7 ? -11
 (A) -10 (B) -9 (C) -8 (D) -10.5
70. Round 2•43 to 1 decimal place:
 (A) 2•4 (B) 2•5 (C) 2•3 (D) 2•44
71. Round 2•27 to 1 decimal place:
 (A) 2•3 (B) 2•2 (C) 2•28 (D) 2

72. Round 27.71 to 1 decimal place:
 (A) 27.72 (B) 27.7 (C) 27.8 (D) 28
73. Round 21.57 to 1 decimal place:
 (A) 21.58 (B) 21.59 (C) 21.5 (D) 21.6
74. Which of these numbers is a square number?
 (A) 21 (B) 36 (C) 41 (D) 88
75. Which of these numbers is a square number?
 (A) 15 (B) 17 (C) 36 (D) 12
76. Which of these numbers is a square number?
 (A) 11 (B) 32 (C) 64 (D) 19
77. $36 = 2 \times 2 \times ?$
 (A) 7 (B) 6 (C) 9 (D) 8
78. $80 = 2 \times 10 \times ?$
 (A) 4 (B) 6 (C) 5 (D) 8 ✓
79. $42 = 2 \times 3 \times ?$
 (A) 7 (B) 6 (C) 9 (D) 8 ✓
80. $48 = 2 \times 2 \times ?$
 (A) 79 (B) 6 (C) 12 (D) 11 ✓
81. $32 = 2 \times 2 \times ?$
 (A) 7 (B) 6 (C) 9 (D) 8 ✓
82. $24 = 3 \times 2 \times ?$
 (A) 4 (B) 6 (C) 5 (D) 8
83. $24 = 4 \times 2 \times ?$
 (A) 4 (B) 6 (C) 2 (D) 3
84. $(3 + 2) \times ? = 10$
 (A) 1 (B) 2 (C) 3 (D) 4
85. $(2 + 2) \times ? = 16$
 (A) 2 (B) 3 (C) 4 (D) 5

86. $(4 + 2) \times ? = 18$
(A) 3 (B) 6 (C) 2 (D) 8
87. $(3 + 3) \times ? = 18$
(A) 1 (B) 3 (C) 4 (D) 2
88. $(3 + 5) \times ? = 24$
(A) 4 (B) 3 (C) 2 (D) 5
89. $2x = 16$. What is x ?
(A) 14 (B) 8 (C) 4 (D) 18
90. $2x = 18$. What is x ?
(A) 9 (B) 20 (C) 16 (D) 36
91. $2x = 14$. What is x ?
(A) 16 (B) 12 (C) 28 (D) 7
92. $3x = 21$. What is x ?
(A) 24 (B) 7 (C) 18 (D) 63
93. $3x = 24$. What is x ?
(A) 21 (B) 27 (C) 8 (D) 72
94. $4x = 16$. What is x ?
(A) 64 (B) 20 (C) 12 (D) 4
95. $5x = 25$. What is x ?
(A) 20 (B) 30 (C) 5 (D) 125
96. How many millimetres in a centimetre?
(A) 1 (B) 10 (C) 100 (D) 1000 ✓
97. How many millimetres in a metre?
(A) 1 (B) 10 (C) 100 (D) 1000 ✓
98. How many centimetres in a metre?
(A) 1 (B) 10 (C) 100 (D) 1000 ✓